

**UZUPEŁNIA ZESPÓŁ NADZORUJĄCY**

**KOD UCZNI**

--	--	--

**PESEL**

--	--	--	--	--	--	--	--	--	--	--	--

*miejsce  
na naklejkę*

**UZUPEŁNIA ZESPÓŁ  
NADZORUJĄCY**

Uprawnienia ucznia  
do nieprzenoszenia  
zaznaczeń na kartę

**EGZAMIN  
W KLASIE TRZECIEJ  
GIMNAZJUM**  
CZĘŚĆ 3. JĘZYK ANGIELSKI  
POZIOM PODSTAWOWY

**21 KWIETNIA  
2017**

**Godzina  
rozpoczęcia:  
9:00**

**Czas pracy:  
do 80 minut**



GA-P5-172

## **Instrukcja dla ucznia**

1. Sprawdź, czy na kolejno ponumerowanych 31 stronach jest wydrukowanych 11 zadań. Ewentualny brak stron lub inne usterki zgłoś nauczycielowi.
2. Czytaj uważnie wszystkie teksty i zadania. Wykonuj zadania zgodnie z poleceniami.
3. Teksty do zadań od 1. do 4. zostaną odtworzone z płyty CD.
4. Rozwiązania zapisuj długopisem lub piórem z czarnym tuszem/atramentem. Nie używaj korektora.
5. W niektórych zadaniach podanych jest kilka odpowiedzi do wyboru, np. od A do F. Wybierz i zaznacz tylko jedną odpowiedź.

**Powodzenia!**

pusta strona

## Zadanie 1. (0–5)

Usłyszysz dwukrotnie pięć tekstów. Na podstawie informacji zawartych w nagraniu w zadaniach 1.1.–1.5. z podanych odpowiedzi wybierz właściwą. Zakreśl literę A, B albo C.

1.1. What is the girl going to eat?

A.

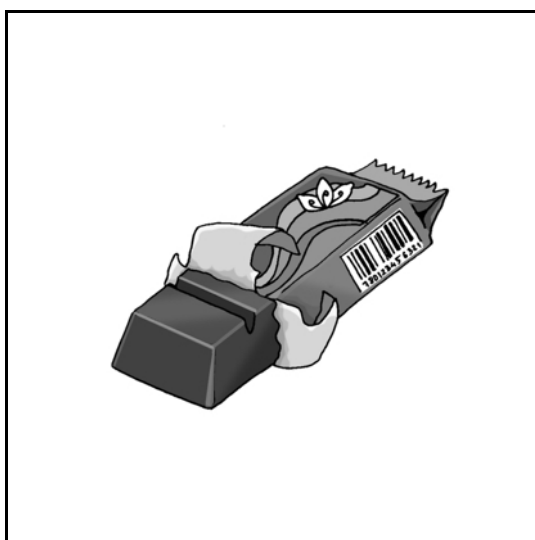

batonik czekoladowy

B.



orzechy

C.

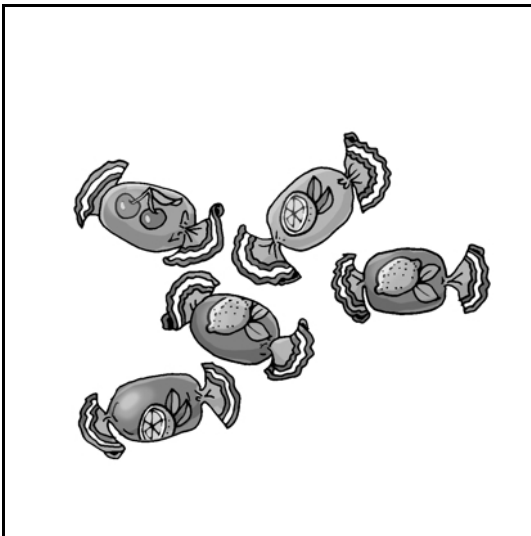

cukierki

## 1.2. What is the boy looking for?

A.



buty sportowe

B.

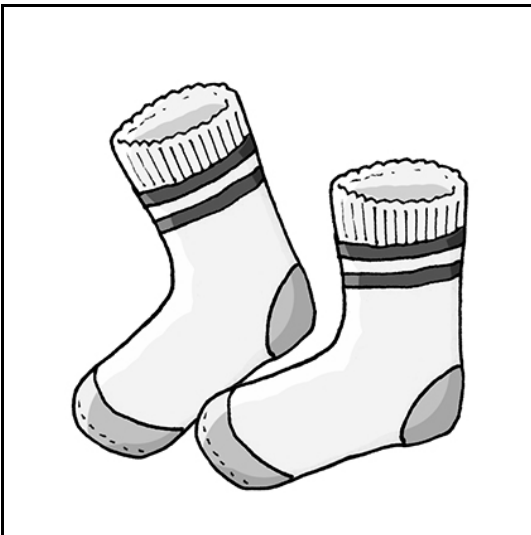

skarpetki

C.



szorty

### 1.3. Where did the girl go yesterday?

A.

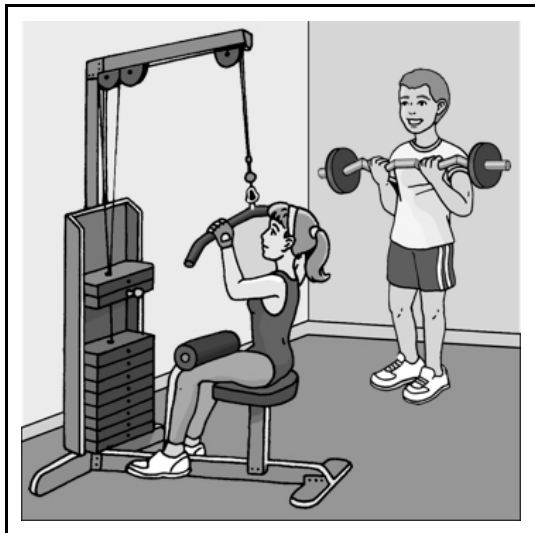

dziewczyna i chłopak ćwiczą na siłowni

B.



dziewczyna jest u lekarza



C.



dziewczyna i chłopak jeżdżą na łyżwach

# 1.4. Where are the people talking?

A.

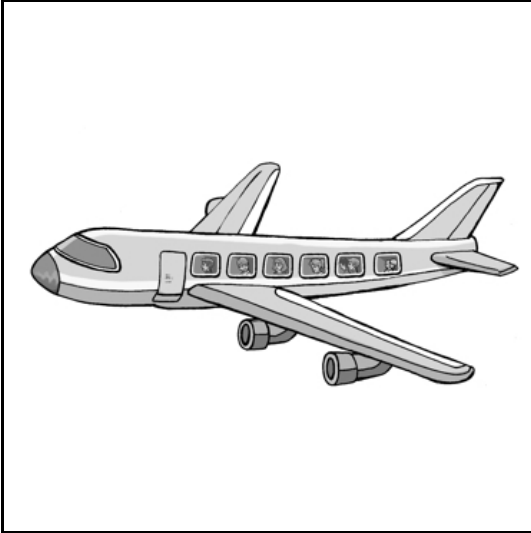

samolot

B.

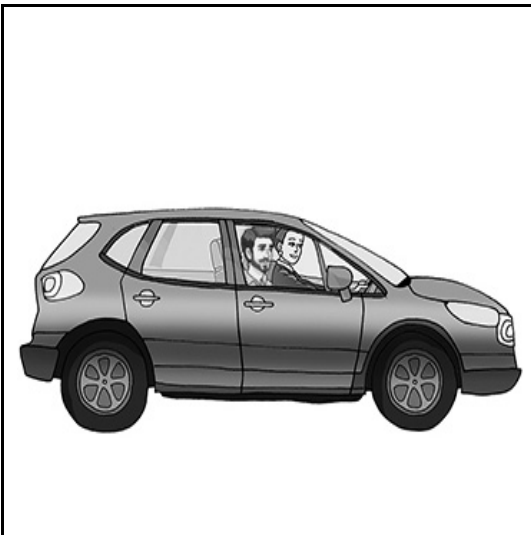

samochód

C.

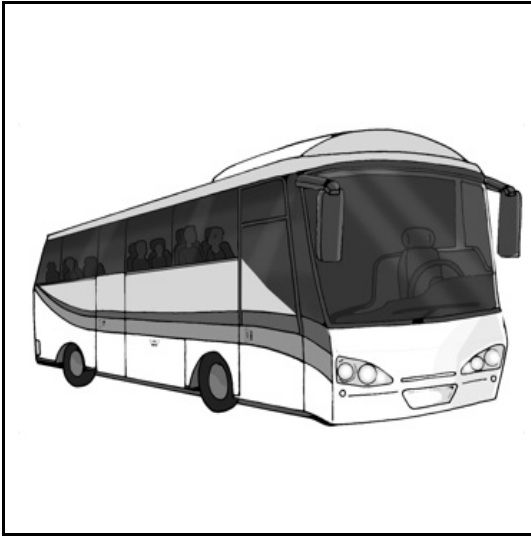

autokar

1.5. Pete is calling Alice to

A. tell her about his last visit to a museum.

B. suggest a visit to a museum.

C. accept her invitation to visit a museum.

## Zadanie 2. (0–4)

Usłyszysz dwukrotnie rozmowę dwójki przyjaciół. Na podstawie informacji zawartych w nagraniu dopasuj do każdej osoby (2.1.–2.4.) cel, na który przeznaczylaby pieniądze wygrane na loterii (A–E). Wpisz odpowiednią literę w każdą kratkę. Uwaga! Jeden cel został podany dodatkowo i nie pasuje do żadnej osoby.

Who?

- |             |                          |
|-------------|--------------------------|
| 2.1. George | <input type="checkbox"/> |
| 2.2. Vicky  | <input type="checkbox"/> |
| 2.3. Martha | <input type="checkbox"/> |
| 2.4. Toby   | <input type="checkbox"/> |

What to spend the money on?

A. helping animals

B. building a sports centre

C. travelling abroad

D. making a film about African animals

E. buying things for pupils

### Zadanie 3. (0–3)

Usłyszysz dwukrotnie komunikat dla uczestników wyjazdu szkolnego.

Zdecyduj, które ze zdań 3.1.–3.3. są zgodne z treścią nagrania (P – Prawda), a które nie (F – Fałsz). Zakreśl literę P albo F.

3.1. The students did some sightseeing the day before.

P  F

3.2. The students will spend less than four hours in the safari park.

P  F

3.3. The speaker tells the students how to behave in the safari park.

P  F

## Zadanie 4. (0–4)

Usłyszysz dwukrotnie cztery wypowiedzi (4.1.–4.4.). Do każdej z nich dobierz właściwą reakcję (A–E). Wpisz rozwiązania do tabeli. Uwaga! Jedna reakcja została podana dodatkowo i nie pasuje do żadnej wypowiedzi.

- A. I went there yesterday.
- B. Sure, but only for an hour.
- C. Nothing special. Why are you asking?
- D. Since the last holidays.
- E. They might be in the drawer.

4.1.	
4.2.	
4.3.	
4.4.	

## Zadanie 5. (0–3)

Uzupełnij poniższe minidialogi (5.1.–5.3.), wybierając spośród podanych opcji brakującą wypowiedź jednej z osób. Zakreśl literę A, B albo C.

5.1.

X: Can you pass me some bread, please?

Y: \_\_\_\_\_

A. Never mind.

B. You're very kind.

C. Here you are.



5.2.

X: Which way should I take now?

Y: \_\_\_\_\_

A. Turn left, then go straight on.

B. Take only what's necessary.

C. Put that sign the other way round.

5.3.

X: \_\_\_\_\_

Y: Peter does.

A. Who else likes them?

B. Who do they like?

C. Who do you like best?

## Zadanie 6. (0–3)

Dla każdej z opisanych sytuacji (6.1.–6.3.) wybierz właściwą reakcję. Zakreśl literę A, B albo C.

6.1. Kolega z Anglii informuje Cię, że nie może Cię odwiedzić. Co powiesz, wyrażając swoje rozczarowanie?

- A. What a pity!
- B. It doesn't matter.
- C. Same to you.

6.2. Masz nowe okulary przeciwsłoneczne. Jak zapytasz koleżankę o opinię na ich temat?

- A. Do you like your new sunglasses?
- B. How do you like my sunglasses?
- C. What are her sunglasses like?

6.3. Dzwoni do Ciebie sąsiad, ale nie możesz w tej chwili rozmawiać. Co mu powiesz?

A. I'm sorry for calling so late.

B. I had a few calls to make.

C. I'll call you back.

### **Zadanie 7. (0–4)**

Przeczytaj teksty 7.1.–7.4. Do każdego z nich dobierz odpowiednie zdanie (A–E).

Wpisz rozwiązania do tabeli. Uwaga!

Jedno zdanie zostało podane dodatkowo i nie pasuje do żadnego tekstu.

7.1.

Book lovers are welcome at the Town Library

–Exchange opinions about your favourite books.

–Talk to famous writers.

–Buy different titles for £1 each.

Join us every Friday at 5 p.m.

7.2.

School market

Tomorrow, 9.00 a.m., at our gym.

Come if you need a book for any school subject.

Don't forget to bring your old coursebooks!

You can give them to younger pupils.

7.3.

“Jeffrey Archer is brilliant at storytelling.

He keeps the readers interested till the very end of each book.”

Erica Wagner, Literary Editor, The Times

7.4.

Are you good at writing?

If so, write a story for teenagers and win a meeting with J. K. Rowling – the author of “Harry Potter”.

Show everyone what you can do!

Register before Friday, 21st June, and send your story to [www.teenreview.edu.uk](http://www.teenreview.edu.uk)

This text

A. is about a competition.

B. invites you to a meeting which takes place once a week.

C. informs you where you can win a book.

D. suggests what to do with the books you don't use anymore.

E. presents an opinion about a writer.

7.1.	
7.2.	
7.3.	
7.4.	

## **Zadanie 8. (0–4)**

Przeczytaj teksty. W zadaniach 8.1.–8.4. z podanych odpowiedzi wybierz właściwą, zgodną z treścią tekstów. Zakreśl literę A, B albo C.

Tekst 1.

Hi Keith,

the CD I gave you is not the one with the photos from our end-of-school ceremony.

The one you've got has my holiday pictures on it. I've just found the CD you wanted. I'll give it to you tomorrow.

Dave

Tekst 2.

Cindy,

I took the wrong bus on the way to the cinema and now I'm waiting for another one to go back. Just leave my ticket at the ticket office.

Steve

- 8.1. Dave and Steve are writing about
- A. going out with someone.
  - B. making a mistake.
  - C. leaving something in the wrong place.

Hi Lisa,

Sorry to hear about your phone. Don't worry. I think you should e-mail Adam. I've heard he's got a new mobile. I'm sure he'll lend you his old one until you find yours or buy something new.

All the best,

Sara

- 8.2. From the message we know that Lisa
- A. has lost her phone.
  - B. has bought a new phone.
  - C. has lent Adam her old phone.

Agony Aunt's answer to Rachel:  
Cheer up, Rachel! I understand you're sad because you had to give the bigger room to your baby sister. But when you decorate your new room with your own posters and whatever else you like, even a little bedroom will look great.

8.3. Rachel is unhappy because she  
A. can't have posters in her room.  
B. has to share a room with her sister.  
C. has a smaller room than before.

Sam,  
Guess what's happened! Harry has invited me on a date. I'm so excited. Do you have any suggestions about what I should wear? Call me, please.  
Fiona



- 8.4. Fiona is writing
- A. to ask Sam for advice.
  - B. to offer Sam her help.
  - C. to invite Sam somewhere.

### **Zadanie 9. (0–4)**

Przeczytaj opisy trzech psów (A–C) oraz zdania ich dotyczące (9.1.–9.4.). Do każdego zdania dopasuj właściwy opis. Wpisz rozwiązania do tabeli. Uwaga! Jeden opis pasuje do dwóch zdań.

#### Four-legged friends

##### A. Dixie

When Aunt Helen decided to move abroad, she gave her dog Dixie to her nephew, Ron. He often takes Dixie to the park. She enjoys running and is always unhappy when it's time to return home. The dog shares her sleeping basket with the cat that Ron brought home two months ago.

## B. Luna

Adam always wanted to have a pet. When he turned thirteen, his parents finally decided to take a small dog, eight-year-old Luna, from a shelter. Luna loves playing with Adam in his room or running after cats and birds in the park in any kind of weather. When they get back home, Luna jumps onto Adam's favourite armchair. She loves sleeping there.

## C. Coco

Jack found Coco in the street. When she was a puppy, she loved hiding pieces of food under the furniture all over the flat. Coco likes going out but she is also happy to get back home. When it rains, she runs home as quickly as possible. The dog also loves watching the parrot that Jack keeps in a cage.

This dog

9.1.	doesn't want to stay outside in bad weather.	
9.2.	is the only pet in the house.	
9.3.	belonged to another member of the family earlier.	
9.4.	sleeps on a piece of her owner's furniture.	

## Zadanie 10. (0–3)

Przeczytaj tekst. Spośród wyrazów podanych w ramce wybierz te, które poprawnie uzupełniają luki 10.1.–10.3. Wpisz odpowiednią literę (A–F) obok numeru każdej luki. Uwaga! Trzy wyrazy zostały podane dodatkowo i nie pasują do żadnej luki.

A. abroad
B. arrived
C. foreign
D. had
E. made
F. travelled

## Exploration

In 2012, John Nilson, a famous explorer, finished his most difficult expedition. He called it Pole2Pole. He 10.1. \_\_\_\_\_ in different ways – he walked, skied and biked through all the continents. Some places were very cold and others extremely hot. He 10.2. \_\_\_\_\_ many adventures, for example, he was chased by bears once. When someone asked what exploration means to him, he said, “Exploration is learning new things, learning how to play the piano, learning to speak another 10.3. \_\_\_\_\_ language or even learning how to cook.” So, are you an explorer?

## Zadanie 11. (0–3)

Przeczytaj tekst. Wybierz poprawne uzupełnienie luk 11.1.–11.3. Zakreśl literę A, B albo C.

Hi Greg,

As you know last September I started taking guitar lessons. At first it was hard and my fingers really hurt. But now it's no longer a problem and I can play the guitar 11.1. \_\_\_\_\_ hours. My friends say I'm quite good and have invited me 11.2. \_\_\_\_\_ at a school concert next Friday. I'm thrilled! I will perform with Judith, who is going to sing a few songs. You must come and see 11.3. \_\_\_\_\_ on stage.

The concert starts at 2 p.m. I hope you can make it.

Love, Lucy

Dalszy ciąg zadania 11. znajduje się na następnej stronie.

11.1.

A. for

B. since

C. until

11.2.

A. playing

B. to play

C. play

11.3.

A. our

B. us

C. we













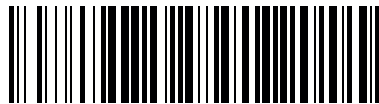

## WYPEŁNIA ZESPÓŁ NADZORUJĄCY

KOD UCZNI

PESEL

miejsce  
na naklejkę

## WYPEŁNIA EGZAMINATOR

Nr zad.	Odpowiedzi		
---------	------------	--	--

1.1	<input type="checkbox"/>	<input type="checkbox"/>	<input type="checkbox"/>		
1.2	<input type="checkbox"/>	<input type="checkbox"/>	<input type="checkbox"/>		
1.3	<input type="checkbox"/>	<input type="checkbox"/>	<input type="checkbox"/>		
1.4	<input type="checkbox"/>	<input type="checkbox"/>	<input type="checkbox"/>		
1.5	<input type="checkbox"/>	<input type="checkbox"/>	<input type="checkbox"/>		
2.1	<input type="checkbox"/>	<input type="checkbox"/>	<input type="checkbox"/>	<input type="checkbox"/>	<input type="checkbox"/>
2.2	<input type="checkbox"/>	<input type="checkbox"/>	<input type="checkbox"/>	<input type="checkbox"/>	<input type="checkbox"/>
2.3	<input type="checkbox"/>	<input type="checkbox"/>	<input type="checkbox"/>	<input type="checkbox"/>	<input type="checkbox"/>
2.4	<input type="checkbox"/>	<input type="checkbox"/>	<input type="checkbox"/>	<input type="checkbox"/>	<input type="checkbox"/>
3.1	<input type="checkbox"/>	<input type="checkbox"/>			
3.2	<input type="checkbox"/>	<input type="checkbox"/>			
3.3	<input type="checkbox"/>	<input type="checkbox"/>			
4.1	<input type="checkbox"/>	<input type="checkbox"/>	<input type="checkbox"/>	<input type="checkbox"/>	<input type="checkbox"/>
4.2	<input type="checkbox"/>	<input type="checkbox"/>	<input type="checkbox"/>	<input type="checkbox"/>	<input type="checkbox"/>
4.3	<input type="checkbox"/>	<input type="checkbox"/>	<input type="checkbox"/>	<input type="checkbox"/>	<input type="checkbox"/>
4.4	<input type="checkbox"/>	<input type="checkbox"/>	<input type="checkbox"/>	<input type="checkbox"/>	<input type="checkbox"/>
5.1	<input type="checkbox"/>	<input type="checkbox"/>	<input type="checkbox"/>		
5.2	<input type="checkbox"/>	<input type="checkbox"/>	<input type="checkbox"/>		
5.3	<input type="checkbox"/>	<input type="checkbox"/>	<input type="checkbox"/>		

Nr zad.	Odpowiedzi		
---------	------------	--	--

6.1	<input type="checkbox"/>	<input type="checkbox"/>	<input type="checkbox"/>		
6.2	<input type="checkbox"/>	<input type="checkbox"/>	<input type="checkbox"/>		
6.3	<input type="checkbox"/>	<input type="checkbox"/>	<input type="checkbox"/>		
7.1	<input type="checkbox"/>	<input type="checkbox"/>	<input type="checkbox"/>	<input type="checkbox"/>	<input type="checkbox"/>
7.2	<input type="checkbox"/>	<input type="checkbox"/>	<input type="checkbox"/>	<input type="checkbox"/>	<input type="checkbox"/>
7.3	<input type="checkbox"/>	<input type="checkbox"/>	<input type="checkbox"/>	<input type="checkbox"/>	<input type="checkbox"/>
7.4	<input type="checkbox"/>	<input type="checkbox"/>	<input type="checkbox"/>	<input type="checkbox"/>	<input type="checkbox"/>
8.1	<input type="checkbox"/>	<input type="checkbox"/>	<input type="checkbox"/>		
8.2	<input type="checkbox"/>	<input type="checkbox"/>	<input type="checkbox"/>		
8.3	<input type="checkbox"/>	<input type="checkbox"/>	<input type="checkbox"/>		
8.4	<input type="checkbox"/>	<input type="checkbox"/>	<input type="checkbox"/>		

Nr zad.	Odpowiedzi		
---------	------------	--	--

9.1	<input type="checkbox"/>	<input type="checkbox"/>	<input type="checkbox"/>			
9.2	<input type="checkbox"/>	<input type="checkbox"/>	<input type="checkbox"/>			
9.3	<input type="checkbox"/>	<input type="checkbox"/>	<input type="checkbox"/>			
9.4	<input type="checkbox"/>	<input type="checkbox"/>	<input type="checkbox"/>			
10.1	<input type="checkbox"/>	<input type="checkbox"/>	<input type="checkbox"/>	<input type="checkbox"/>	<input type="checkbox"/>	<input type="checkbox"/>
10.2	<input type="checkbox"/>	<input type="checkbox"/>	<input type="checkbox"/>	<input type="checkbox"/>	<input type="checkbox"/>	<input type="checkbox"/>
10.3	<input type="checkbox"/>	<input type="checkbox"/>	<input type="checkbox"/>	<input type="checkbox"/>	<input type="checkbox"/>	<input type="checkbox"/>
11.1	<input type="checkbox"/>	<input type="checkbox"/>	<input type="checkbox"/>			
11.2	<input type="checkbox"/>	<input type="checkbox"/>	<input type="checkbox"/>			
11.3	<input type="checkbox"/>	<input type="checkbox"/>	<input type="checkbox"/>			



--	--	--	--	--	--	--	--	--

**KOD EGZAMINATORA**

.....  
Czytelny podpis egzaminatora